

Flexible & Customizable Pressure Transmitter MPM489S



Applications

- Oil&Gas
- Hydraulic and pneumatic control
- Machinery manufacturing
- Electric power
- Hydrology and water resources

Features

- Intrinsically safe, Ex ia IIC T4 Ga
- ATEX, IECEx, Ex II 1 G Ex ia IIC T4 Ga
- CE approved

Introduction

MPM489S Pressure Transmitter is developed for general highly stable industry. It combines advanced digital technology with piezoresistive pressure sensing techniques and incorporates digital temperature compensation and nonlinear error correction. The transmitter features a compact, integrated design and provides a standard output signal. Key features include lightweight construction, a wide measurement range, and exceptional stability, making it ideal for the precise measurement requirements of automation control system. It is available with intrinsically safe configurations, making it suitable for use in hazardous areas.

Specifications

Range	-100kPa...0kPa ~ 10kPa...100MPa
Overpressure	≤ 2 times FS or 110MPa (min. Value is valid)
Pressure type	Gauge G, Absolute A, Sealed Gauge S, Positive/Negative N
Accuracy	Refer to “Measuring Range & Accuracy Table”
Long-term stability	±0.2%FS/year
Operating temperature	-40°C~ 100°C (B1, B4, B8)
	-20°C~ 70°C (B2, cable material: PE)
	-20°C~ 80°C (B2 cable material: PUR)
	-30°C~ 80°C (Intrinsically safe explosion-proof, B1, B8) -20°C~ 70°C Intrinsically safe explosion-proof, B2) -30°C~ 80°C (Intrinsically safe explosion-proof, B4)
Storage temperature	-40°C~ 120°C (B1, B8)
	-20°C~ 85°C (B2, B4)
Vibration	10g, 55Hz ~ 2000Hz
Shock	100g, 11ms
IP rating	IP65 (B1, B8)
	IP67 (B4)
	IP68 (B2)
Weight	≤ 270g

Measuring Range & Accuracy Table

Gauge Pressure G									
Unit	Measuring Range	Accuracy	Overpressure	Code	Unit	Measuring Range	Accuracy	Overpressure	Code
kPa	0 - 7	±0.5%FS	15	K007	mbar	0 - 70	±0.5%FS	150	m070
	0 - 10		20	K010		0 - 100		200	m100
	0 - 20		40	K020		0 - 200		500	m200
	0 - 25	±0.25%FS	50	K025		0 - 250	500	m250	
	0 - 40		100	K040		0 - 400	1000	m400	
	0 - 50		100	K050		0 - 500	1000	m500	
	0 - 60		100	K060		0 - 600	1200	m600	
	0 - 70		100	K070		0 - 700	1400	m700	
	0 - 80		200	K080		0 - 800	1600	m800	
	0 - 90		200	K090		0 - 900	1800	m900	
	0 - 100		200	K100					
	0 - 160		300	K160					
	0 - 200	400	K200						
	0 - 250	500	K250						
	0 - 300	600	K300						
	0 - 400	1000	K400						
	0 - 500	1000	K500						
	0 - 600	1000	K600						
	0 - 700	1400	K700						
0 - 800	1600	K800							
0 - 900	1800	K900							
mbar	0 - 1	±0.25%FS	2	B001	bar	0 - 1	±0.25%FS	2	B001
	0 - 1.6		3	B1D6		0 - 1.6		3	B1D6
	0 - 2		4	B002		0 - 2		4	B002
	0 - 2.5		5	B2D5		0 - 2.5		5	B2D5
	0 - 3		6	B003		0 - 3		6	B003
	0 - 4		10	B004		0 - 4		10	B004
	0 - 5		10	B005		0 - 5		10	B005
	0 - 6		10	B006		0 - 6		10	B006
	0 - 7		14	B007		0 - 7		14	B007
	0 - 8		16	B008		0 - 8		16	B008
	0 - 9		18	B009		0 - 9		18	B009
	0 - 10		20	B010		0 - 10		20	B010
	0 - 16		30	B016		0 - 16		30	B016
	0 - 20		40	B020		0 - 20		40	B020
	0 - 25		50	B025		0 - 25		50	B025
0 - 30	60	B030	0 - 30	60	B030				
0 - 35	60	B035	0 - 35	60	B035				
MPa	0 - 1	±0.25%FS	2	M1D0					
	0 - 1.6		3	M1D6					
	0 - 2		4	M2D0					
	0 - 2.5		5	M2D5					
	0 - 3		6	M3D0					
	0 - 3.5		6	M3D5					
psi	0 - 1.5	±0.5%FS	3	P1D5					
	0 - 3		6	P003					
	0 - 5		10	P005					
	0 - 10	±0.25%FS	15	P010					
	0 - 15		20	P015					
	0 - 30		45	P030					
	0 - 60		150	P060					
	0 - 100		150	P100					
	0 - 160		300	P160					
	0 - 200		300	P200					
	0 - 300		450	P300					
	0 - 400		750	P400					
0 - 500	750	P500							

Sealed Gauge Pressure S									
Unit	Measuring Range	Accuracy	Overpressure	Code	Unit	Measuring Range	Accuracy	Overpressure	Code
MPa	0 - 3.5	±0.25%FS	7	M3D5	bar	0 - 35	±0.25%FS	70	B035
	0 - 4		10	M4D0		0 - 40		100	B040
	0 - 5		10	M5D0		0 - 50		100	B050
	0 - 6		10	M6D0		0 - 60		100	B060
	0 - 7		10	M7D0		0 - 70		100	B070
	0 - 8		15	M8D0		0 - 80		150	B080
	0 - 9		15	M9D0		0 - 90		150	B090
	0 - 10		15	M010		0 - 100		150	B100
	0 - 16		30	M016		0 - 160		300	B160
	0 - 20		30	M020		0 - 200		300	B200
	0 - 25		37.5	M025		0 - 250		450	B250
	0 - 30		45	M030		0 - 300		525	B300
	0 - 35		52.5	M035		0 - 350		375	B350
	0 - 40		60	M040		0 - 400		600	B400
	0 - 50		75	M050		0 - 500		750	B500
	0 - 60		90	M060		0 - 600		900	B600
	0 - 70		100	M070		0 - 700		1000	B700
	0 - 80		100	M080		0 - 800		1000	B800
	0 - 90		100	M090		0 - 900		1000	B900
	0 - 100		110	M100		0 - 1000		1100	B01K

psi	0 - 500	±0.25%FS	750	P500
	0 - 600		1500	P600
	0 - 700		1500	P700
	0 - 800		1500	P800
	0 - 900		1500	P900
	0 - 1000		1500	P01K
	0 - 2000		3000	P02K
	0 - 3000		4500	P03K
	0 - 4000		6000	P04K
	0 - 5000		7500	P05K
	0 - 6000		9000	P06K
	0 - 7000		10500	P07K
	0 - 8000		12000	P08K
	0 - 9000		13500	P09K
	0 - 10000		15000	P10K

Absolute Pressure A

Unit	Measuring Range	Accuracy	Overpressure	Code	Unit	Measuring Range	Accuracy	Overpressure	Code
kPa	0 - 40	±0.5%FS	100	K040	bar	0-1	±0.5%FS	2	B001
	0 - 50		100	K050		0-1.6		3	B1D6
	0 - 60		100	K060		0-2		4	B002
	0 - 70		100	K070		0-2.5		5	B2D5
	0 - 80		200	K080		0-3		6	B003
	0 - 90		200	K090		0-4		10	B004
	0 - 100	200	K100	0-5		10	B005		
	0 - 160	±0.25%FS	300	K160		0-6	10	B006	
	0 - 200		400	K200		0-7	14	B007	
	0 - 250		500	K250		0-8	16	B008	
	0 - 300		600	K300		0-9	18	B009	
	0 - 400		1000	K400		0-10	20	B010	
	0 - 500		1000	K500		0-16	30	B016	
	0 - 600		1000	K600		0-20	40	B020	
	0 - 700		1400	K700		0-25	50	B025	
	0 - 800		1600	K800		0-30	60	B030	
	0 - 900		1800	K900		0-35	60	B035	
							0-40	100	B040
					0-50	100	B050		
				0-60	100	B060			
				0-70	140	B070			
				0-80	160	B080			
				0-90	180	B090			
				0-100	200	B100			
				0-160	300	B160			
				0-200	300	B200			
				0-250	375	B250			
				0-300	350	B300			
				0-350	525	B350			
				0-400	600	B400			
				0-500	750	B500			
				0-600	900	B600			
				0-700	1000	B700			
				0-800	1000	B800			
				0-900	1000	B900			
				0-1000	1100	B01K			
MPa	0 - 1	±0.25%FS	2	M1D0	psi	0 - 5	±0.5%FS	10	P005
	0 - 1.6		3	M1D6		0 - 10		15	P010
	0 - 2		4	M2D0		0 - 15		20	P015
	0 - 2.5		5	M2D5		0 - 30	±0.25%FS	45	P030
	0 - 3		6	M3D0		0 - 60		150	P060
	0 - 3.5		6	M3D5		0 - 100		150	P100
	0 - 4		6	M4D0		0 - 160		300	P160
	0 - 5		10	M5D0		0 - 200		300	P200
	0 - 6		10	M6D0		0 - 300		450	P300
	0 - 7		14	M7D0		0 - 400		750	P400
	0 - 8		16	M8D0		0 - 500		750	P500
	0 - 9		18	M9D0		0 - 600		1500	P600
	0 - 10		20	M010		0 - 700		1500	P700
	0 - 16		30	M016		0 - 800		1500	P800
	0 - 20		30	M020		0 - 900		1500	P900
	0 - 25		37.5	M025		0 - 1000		1500	P01K
	0 - 30		45	M030		0 - 2000		3000	P02K
	0 - 35		52.5	M035		0 - 3000		4500	P03K
	0 - 40		60	M040		0 - 4000		6000	P04K
	0 - 50		75	M050		0 - 5000		7500	P05K
0 - 60	90	M060	0 - 6000	9000	P06K				
0 - 70	100	M070	0 - 7000	10500	P07K				
0 - 80	100	M080	0 - 8000	12000	P08K				
0 - 90	100	M090	0 - 9000	13500	P09K				
0 - 100	110	M100	0 - 10000	15000	P10K				
mbar	0 - 400	±0.5%FS	1000	m400					
	0 - 500		1000	m500					
	0 - 600		1200	m600					
	0 - 700		1400	m700					
	0 - 800		1600	m800					
	0 - 900		1800	m900					

Positive/Negative Pressure N									
Unit	Measuring Range	Accuracy	Overpressure	Code	Unit	Measuring Range	Accuracy	Overpressure	Code
kPa	- 25 - 0	±0.5%FS	50	V025	bar	- 0.25 - 0	±0.5%FS	0.5	VD25
	- 40 - 0		100	V040		1		V0D4	
	- 60 - 0		100	V060		1		V0D6	
	- 100 - 0		150	V100		1.5		V1D0	
	- 3 - +3		10	C033		0.1		C0D3	
	- 5 - +20		30	C520		0.3		C052	
	- 5 - +25		30	C525		0.3		C5D5	
	- 15 - +15		30	C015		0.3		CD15	
	- 20 - +20		30	C020		0.3		C0D2	
	- 25 - +25		50	C025		0.5		CD25	
	- 30 - +30	50	C030	0.5		C003			
	- 50 - +50	100	C050	1		C005			
	- 100 - +60	150	C16B	1.5		C0D6			
	- 100 - +100	300	C11B	2		C101			
	- 100 - +150	300	C1B5	3		C1D5			
	- 100 - +300	500	C13B	5		C103			
	- 100 - +500	1000	C15B	10		C105			
	- 100 - +900	2000	C19B	20		C109			
	- 100 - +1000	2500	C11K	25		C110			
	- 100 - +1500	3000	C1K5	30		C115			
- 100 - +1600	±0.25%FS	3000	C1K6	±0.25%FS	30	C116			
- 100 - +2000	3000	C12K	30	C120					
- 100 - +2400	5000	C24K	50	C124					
- 100 - +2500	5000	C25K	50	C125					
- 100 - +3000	6000	C30K	60	C130					
- 100 - +3500	7000	C35K	70	C135					

psi	-15 - 0	±0.5%FS	20	PF00
	-15 - +10		20	PF10
	-15 - +15		45	PF15
	-15 - +30	±0.25%FS	150	PF30
	-15 - +50		150	PF50
	-15 - +80		300	PF80
	-15 - +100		300	PF1B
	-15 - +150		450	P1B5

Compensation temperature: -20°C~ 60°C;
 Test standard: GB/T 17614.1-2015/IEC60770-1:2010;
 Ambient temperature: 20°C ±5°C

For other measurement ranges, please contact MICROSENSOR

Thermal Error

Zero thermal error	$\pm 0.05\%FS/^{\circ}C$ ($\leq 100kPa$)
	$\pm 0.03\%FS/^{\circ}C$ ($> 100kPa$)
Span thermal error	$\pm 0.05\%FS/^{\circ}C$ ($\leq 100kPa$)
	$\pm 0.03\%FS/^{\circ}C$ ($> 100kPa$)

Output Signals

Output Signal	Supply Voltage	Output Type	Load Resistance
4mA ~ 20mA DC	8V ~ 28V DC	2-wire	$\leq (U-8)/0.02$ (Ω)
1V ~ 5V DC		3-wire	$\geq 10k\Omega$
0V ~ 5V DC			
0.5V ~ 4.5V DC	12V ~ 28V DC		
0V ~ 10V DC	5V \pm 0.5V DC		
0.5V ~ 4.5V DC	8V ~ 28V DC	4-wire	$\leq (U-8)/0.02$ (Ω)
RS485			

Outline Construction

Unit: mm

4-pin connector (B1)	Cable (B2)	M12×1 4-pin connector(B4)	4-pin connector (B8)

Electrical Connection

Definition	4-pin connector (B1、B8)			Cable (B2)			M12×1 4-pin connector (B4)		
	Current 2-wire	Voltage 3-wire	RS485 4-wire	Current 2-wire	Voltage 3-wire	RS485 4-wire	Current 2-wire	Voltage 3-wire	RS485 4-wire
+V	1	1	1	Red	Red	Red	1	1	1
OUT	2	3		Black	White	Null	3	3	
GND	Null	2	2	Null	Black	Black	Null	2	2
RS485A			3			Yellow			3
RS485B						Blue			4

Sensor Sealing

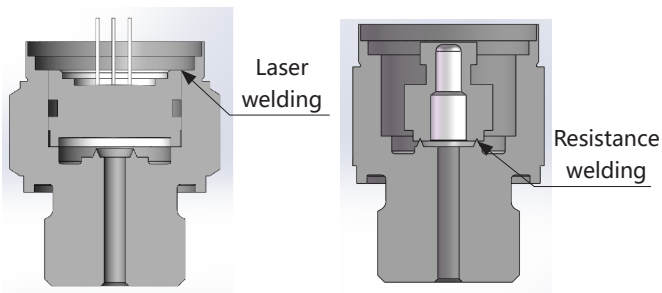

(Measuring Rang < 35MPa) (Measuring Rang ≥ 35MPa)

Construction Materials

Wetted parts

Isolated diaphragm: SS 316L/Titanium alloy/17-4PH (Measuring Rang ≥ 35MPa)

Pressure port: SS 304/SS 316L/Hastelloy C/Titanium alloy

Non-wetted parts

Housing: SS 304/ SS 316L/Titanium alloy

Cable: PE/PUR

Process Connection

Unit: mm

M20× 1.5 Male, face seal (C1)

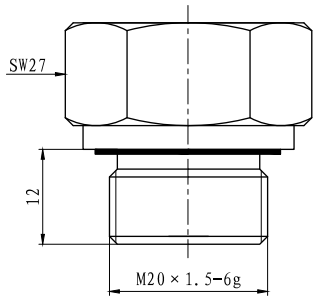

M20×1.5 Male, Waterline (C5)

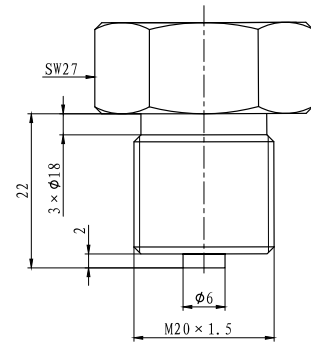

G1/ 4 Male, face seal (C2)

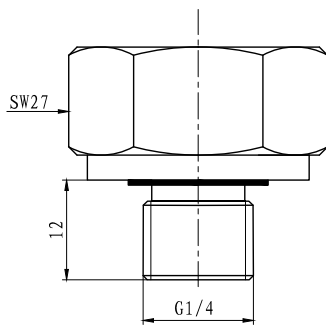

NPT1/4 Male (C6)

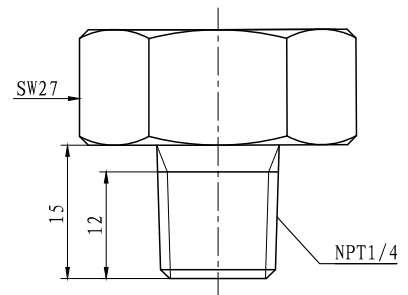

G1/ 2 Male, face seal (C3)

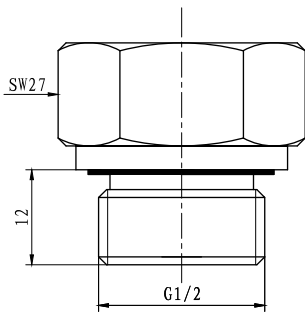

NPT1/8 Male (C7)

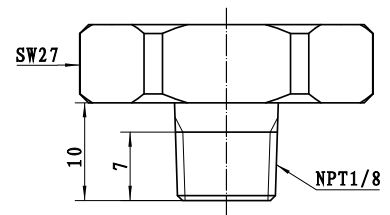

G1/ 4 Female, waterline seal (C4)

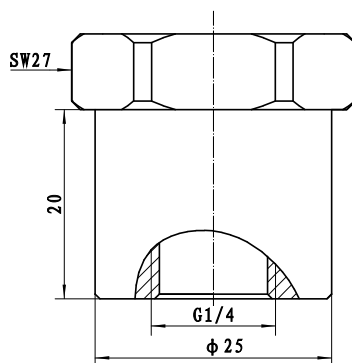

NPT1/ 4 Female(C8)

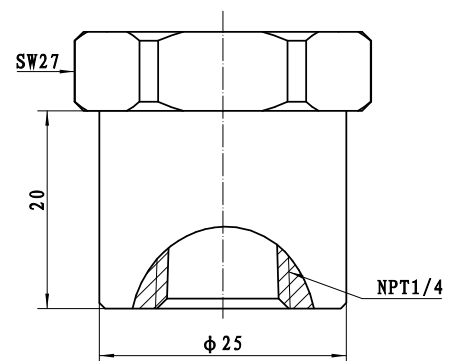

Process Connection

Unit: mm

NPT1/8 Female (C9)

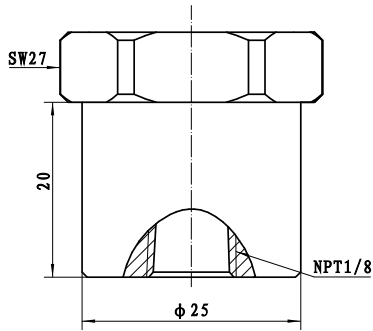

M12×1 Male, 74° cone (C14)

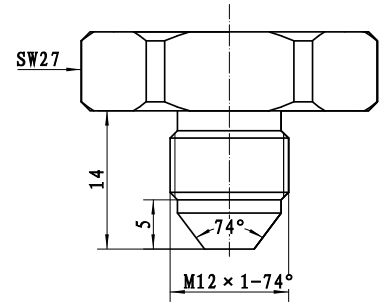

NPT1/2 Male (C10)

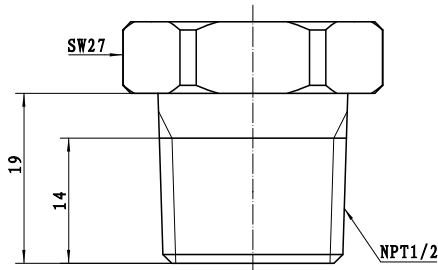

R1/4 Male (C15)

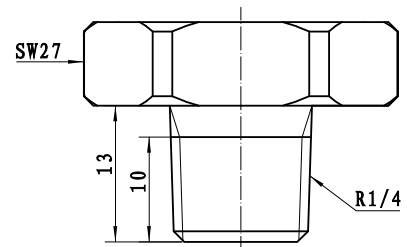

NPT1/2 Female (C11)

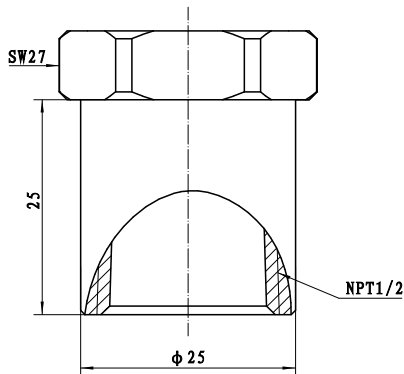

G3/8 Male, face seal (C16)

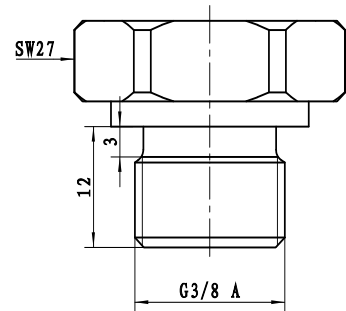

G1/8 Male (C13)

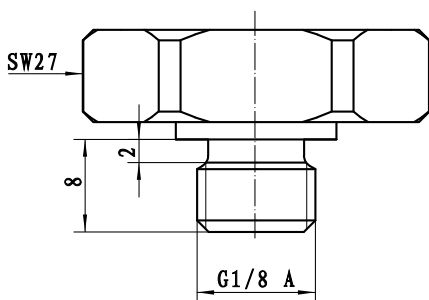

M14×1.5 Male, face seal (C18)

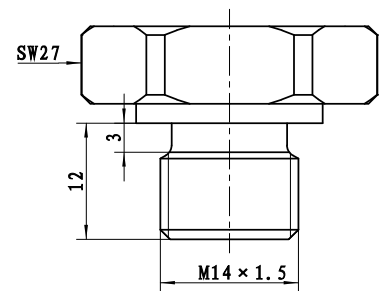

Process Connection

Unit: mm

G3/8 Male, Waterline (C21)

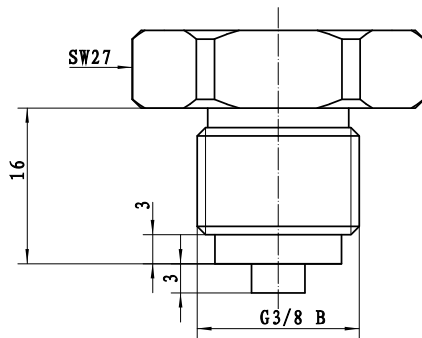

R1/2 Male (C31)

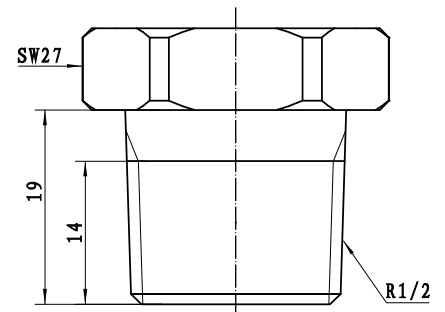

M12×1.5 Male, face seal (C23)

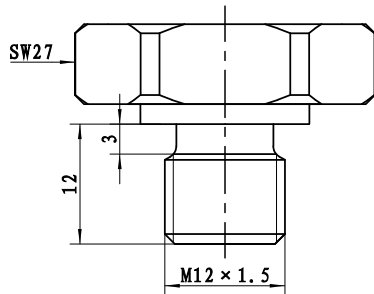

7/16-20 UNF-74° cone(C38)

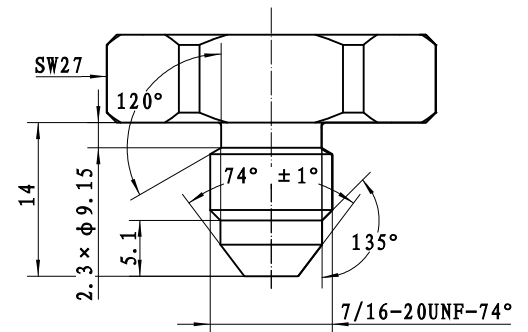

G1/2 Male, Waterline (C25)

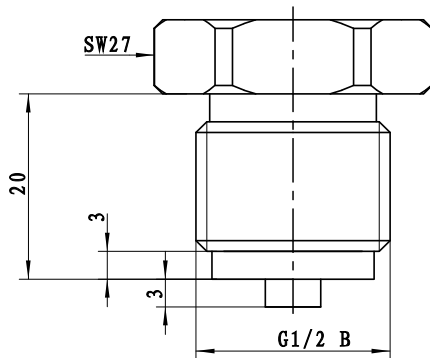

M20×1.5 Flush diaphragm (PC1)

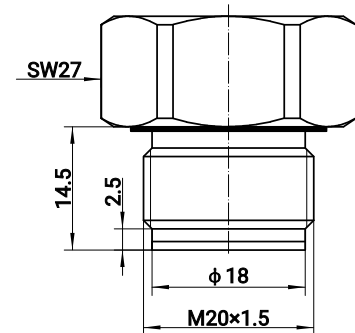

G1/4 Male, Waterline (C30)

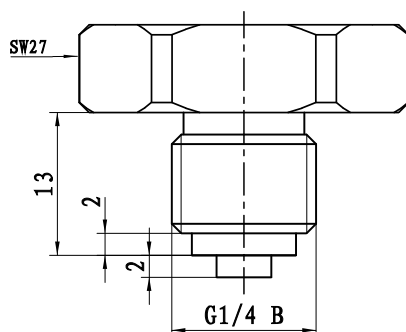

G1/2 Flush diaphragm (PC3)

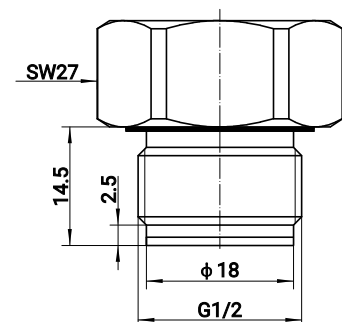

Process Connection

Unit: mm

Hygienic DN25 clamp connection (PD1)

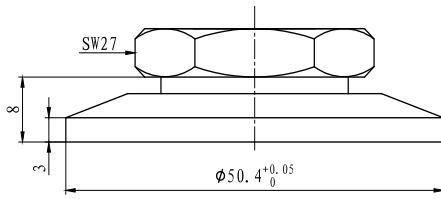

Hygienic DN25 Clamp connection with heat sink (PD1s)

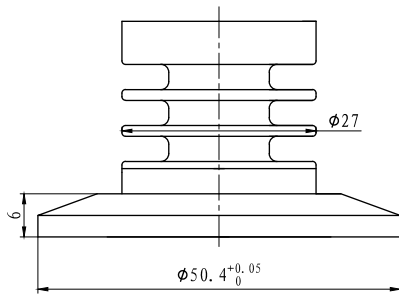

Order Guide

MPM489S Pressure Transmitter

Code	Pressure type		
G	Gauge pressure		
A	Absolute pressure		
S	Sealed gauge pressure		
N	Negative pressure		
Range	Measuring range -100kPa…0kPa ~ 10kPa…100MPa		
XXXX	Range-specific code		
Code	Output signal		
E	4mA ~ 20mA DC		
F	1V ~ 5V DC		
J	0V ~ 5V DC		
V	0V ~ 10V DC		
K	0.5V ~ 4.5V DC		
R8	RS485		
Code	Power supply		
V23	5V±0.5V DC		
V24	8V ~ 28V DC		
V25	12V ~ 28V DC		
Code	Accuracy		
A1	±0.25%FS		
A2	±0.5%FS		
Code	Construction material		
	Isolated diaphragm	Pressure port	Housing
22	SS 316L	SS 304	SS 304
23	SS 316L	SS 316L	SS 304
24	SS 316L	SS 316L	SS 316L
38	Hastelloy C-276	Hastelloy C-276	Hastelloy C-276
40	Titanium TA1	Titanium TC4	Titanium TC4
211 (Measuring Range ≥ 35MPa)	17-4PH	SS 304	SS 304
Code	Sensor sealing		
02	Welding		
Code	Process connection		
C1	M20×1.5 Male, face seal		
C2	G1/4 Male, face seal		
C3	G1/2 Male, face seal		
C4	G1/4 Female		
C5	M20×1.5 Male, waterline seal		
C6	NPT1/4 Male		
C7	NPT1/8 Male		
C8	NPT1/4 Female		
C9	NPT1/8 Male		
C10	NPT1/2 Male		
C11	NPT1/2 Female		
C13	G1/8 Male		
C14	M12×1 Male, 74° cone		
C15	R1/4 Male		
C16	G3/8 Male, face seal		
C18	M14×1.5 Male, face seal		

MPM489S

G

M1D6

E

V23

A1

22

02

The complete spec.

Code	Process connection
C21	G3/8 Male, Waterline
C23	M12×1.5 Male, face seal
C25	G1/2 Male, Waterline
C30	G1/4 Male, Waterline
C31	R1/2 Male
C38	7/16-20 UNF-74° cone
PC1	Flush diaphragm M20× 1.5 Male
PC3	Flush diaphragm G1/ 2 Male
PD1	Hygienic DN25 clamp connection
PD1s	Hygienic DN25 Clamp connection with heat sink
Code	Process connection sealing
N	None(not optional for C4, C6, C7, C8, C9, C10, C11, C15, C31, PD1, PD1s)
1	NBR
2	FKM
3	EPDM
4	Copper (C5 required)
Code	Electrical connection
B1	4-pin connector
B2	Cable
B4	M12×1 4-pin connector
B8	Mini 4-pin connector
Code	Cable material (optional only for B2 cable)
N	None (non-cable connection option)
P1	PE (Standard)
P2	PUR
Code	Cable length (Unit: m) (optional only for B2 cable)
N	None (non-cable connection option)
L001	1
L1D5	1.5
L002	2
L003	3
L004	4
L005	5
L006	6
L007	7
L008	8
L009	9
L010	10
Code	Certification requirement
N	None
y	ATEX Ex ia IIC T4 Ga/IECEX Ex ia IIC T4 Ga
Code	Accessory
N	No accessory

C1

1

B1

N

N

N

N

The complete spec.

Notes

- 1.Refer to the "Measuring Range" on page 2 for product accuracy.
- 2.The minimum operating temperature of FKM O-ring is -20° C, while EPDM O-ring is -40° C.
- 3.Please note that for 5V DC powered products, the cable length must be less than 10m if connected.
- 4.If a metrology verification certificate is required, or there are any other special requirements, please consult with the MICROSENSOR and specify them in the order.