

MDM7000-GP-T/AP-T

Smart Flange Mounted

Gauge/Absolute Pressure Transmitter



Introduction

MDM7000-GP-T/AP-T smart flange mounted gauge/absolute pressure transmitter adopts advanced monocrystalline silicon piezoresistive technology. The product is used to measure the level, density, and pressure of liquid, gas or steam, and then converts the pressure signal into 4mA~20mA DC analog current signal output, and can realize supports setting, monitoring and other functions through communication equipment. It is suitable for the demanding process chemical industry.

Feature

- Monocrystalline silicon piezoresistive sensor technology with stable performance, and high accuracy up to 0.1%FS.
- High overload protection diaphragm to achieve high pressure overload protection function.
- Adopts high performance EMC protection circuit module with strong anti-interference ability.

Application

- Oil and gas industry
- Food processing
- Pulp and Paper
- Power and Energy
- Chemical Industry
- Marine Equipment

Specification

GP-T accuracy	±0.1%, ±0.2% URL See the specifications for details
AP-T accuracy	± 0.1%, ±0.2% URL See the specifications for details
GP-T range	0.4bar~100bar, see the ordering table
AP-T range	0.4bar~10bar, see the ordering table
Ambient temperature effects	Total impact per 10°C in the range of -20°C~80°C: ± (0.5+0.15TD) %SPAN
Power supply effect	When the supply voltage varies from 10.5V/16.5V to 55V DC, the zero and span change should be less than ±0.005%URL/V.
Mounting position effects	Transmitter installation may produce a zero-point error that can be corrected by zero adjustment without span effect.
Vibration effect	< 0.1%URL as per GB/T18271.3/IEC61298-3
Output signal	4mA~20mA DC+HART
Protection rating	IP67
Weight	About 1.61kg (without mounting bracket and process connection parts)

Accuracy

① Stated reference accuracy include linearity (BFSL) , hysteresis, and repeatability as per the standard and reference test conditions.

Calibration Temperature: 20°C ±5°C , based on Zero value.

② The total performance of the product includes reference accuracy and ambient temperature influences, and the results are based on DN50 flange, 316L material

Linear output accuracy	GP-T	TD≤5	±0.1%SPAN	0.4bar,2.5bar,10bar,30bar,100bar
		5<TD<10	±0.2%SPAN	
	AP-T	TD≤5	±0.1%SPAN	
		5<TD<10	±0.2%SPAN	

Note: TD represents the turn down ratio, TD= Maximum range / Current range, [Maximum range = URL (range starts with 0, same as factory calibration range); Current range = SPAN (equivalent to |URV-LRV|)].

Range

Model	Nominal Range	Min. Range	Lower (LRL)	Upper (URL)	Overload
GP-T	0.4bar	0.1bar	-0.4bar	0.4bar	10bar
	2.5bar	0.25bar	-1bar	2.5bar	40bar
	10bar	1bar	-1bar	10bar	60bar
	30bar	3bar	-1bar	30bar	150bar
	100bar	10bar	-1bar	100bar	200bar
AP-T	0.4bar	0.2bar	0bar	0.4bar	10bar
	2.5bar	0.5bar	0bar	2.5bar	40bar
	10bar	2bar	0bar	10bar	60bar

LRV/URV setting: the lower limit value (LRV) and upper limit value (URV) are achieved between the upper and lower limits. If $IURV I \geq ILRV I$, IURV I must be larger than the minimum pressure; if $IURV I \leq ILRV I$, ILRV I must be larger than the minimum pressure.

Overload value: This is the sensor overload pressure, and the actual overload pressure depends on the connection specifications of the connection process.

Power Supply and Load Requirements

Item	Condition
Power supply	HART communication protocol: 16.5V~55V DC
	Intrinsically safe HART communication protocol: 18.5V~28V DC
Load resistance	0Ω~2119Ω (working state) 250Ω~600Ω(HART communication)
Transmission distance	< 1000m
Power consumption	
4mA~20mA	≤500mW@24V DC,20.8mA
Modbus-RTU/RS485	≤240mW@24VDC,10mA

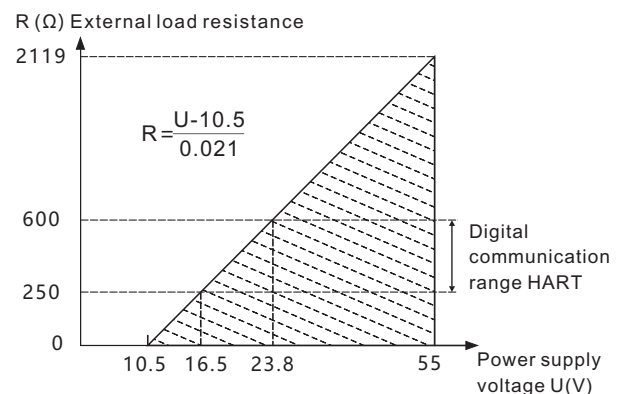

Note: The supply voltage is selectable to 10.5V, please consult engineers for details.

Environment Condition

Items	Condition	
Working temperature	-40°C ~85°C ,LCD display:-20°C ~70°C	
Storage temperature	-40 °C ~100°C ,LCD display:-40°C ~85°C	
Media temperature	Silicone oil:-40°C~200°C	
	High-temperature silicon oil:0°C~315°C	
	Hygienic filler:-10°C~180°C	
Working humidity	5%RH~100%RH@40°C	
Hazardous area *	PCEC	Ex db IIC T6 Gb Ex ia IIC T4 Ga
	ATEX	Ex db IIC T6 Gb,Ex tb IIIC T70°C Db Ex ia IIC T4 Ga
	IECEX	Ex db IIC T6 Gb,Ex tb IIIC T70°C Db Ex ia IIC T4 Ga
	CSA	Class I,Division 1,Group A,B,C and D T6 Class II,Division 1 Group E,F and G T70°C Class III
* Please consult engineers for details		

Electromagnetic Compatibility

No	Test Items	Basic Standards	Test Conditions	Performance Level
1	Radiated interference	GB/T 9254.1/CISPR 32	30MHz ~ 1000MHz	Qualified
2	Conducted interference (DC power port)	GB/T 9254.1/CISPR 32	0.15MHz ~ 30MHz	Qualified
3	Electrostatic discharge immunity test (ESD)	GB/T 17626.2/IEC61000-4-2	8kV (Contact), 8kV (Air)	B
4	Immunity to radio frequency EM-fields	GB/T 17626.3/IEC61000-4-3	10V/m (80MHz ~ 1GHz)	A
5	Power frequency magnetic field Immunity test	GB/T 17626.8/IEC61000-4-8	30A/m	A
6	Electrical fast transient / Burst Immunity test	GB/T 17626.4/IEC61000-4-4	4kV(5/50ns,100kHz)	B
7	Surge immunity requirements	GB/T 17626.5/IEC61000-4-5	1kV (Line to line) 2kV (Line to ground) (1.2/50μs)	B
8	Immunity to conducted disturbances induced by radio frequency fields	GB/T 17626.6/IEC61000-4-6	3V(150kHz ~ 80MHz)	A
<p>Note: Performance level A: The performance within the limits of normal technical specifications. Performance level B: Temporary reduction or loss of functionality or performance, it can restore itself. The actual operating conditions, storage, and data will not be changed.</p>				

Time Index

Damping time constant: equals to the combined damping time of electronic components and sensor module.
Electronic components damping time: 0s~100s configurable
Sensor module damping time(sensor isolated diaphragm and filled silicone oil): ≤ 0.2s
Turn-on time: ≤ 6s
Factory reset time: ≤ 31s

Dimension

unit: mm

MDM7000 With Display (Standard connection)

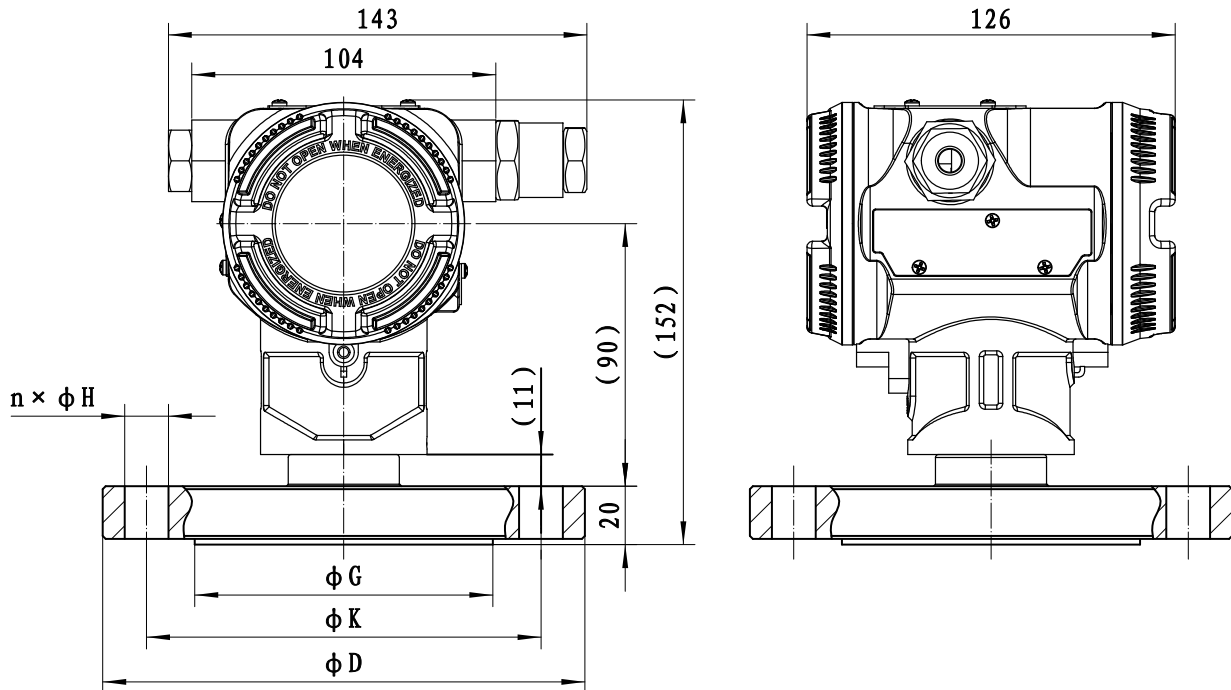

MDM7000 Without Display (Standard connection)

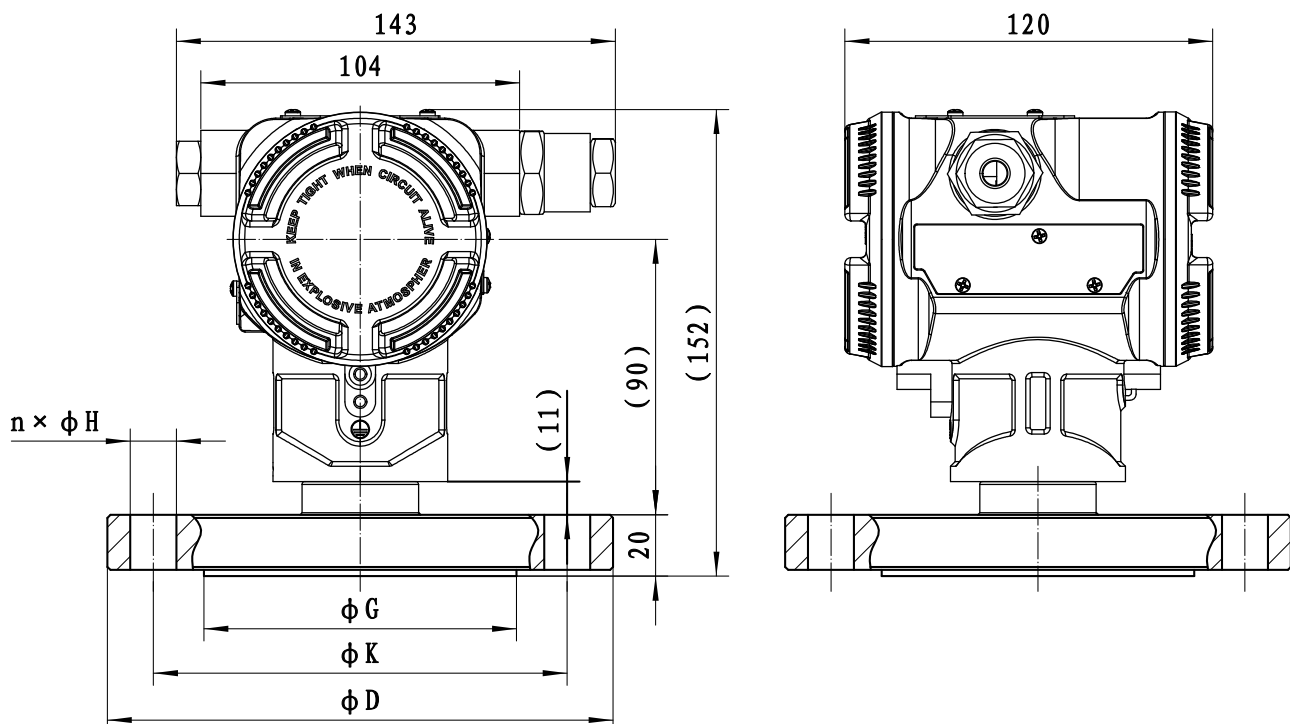

MDM7000 With Display (Heatsink connection)

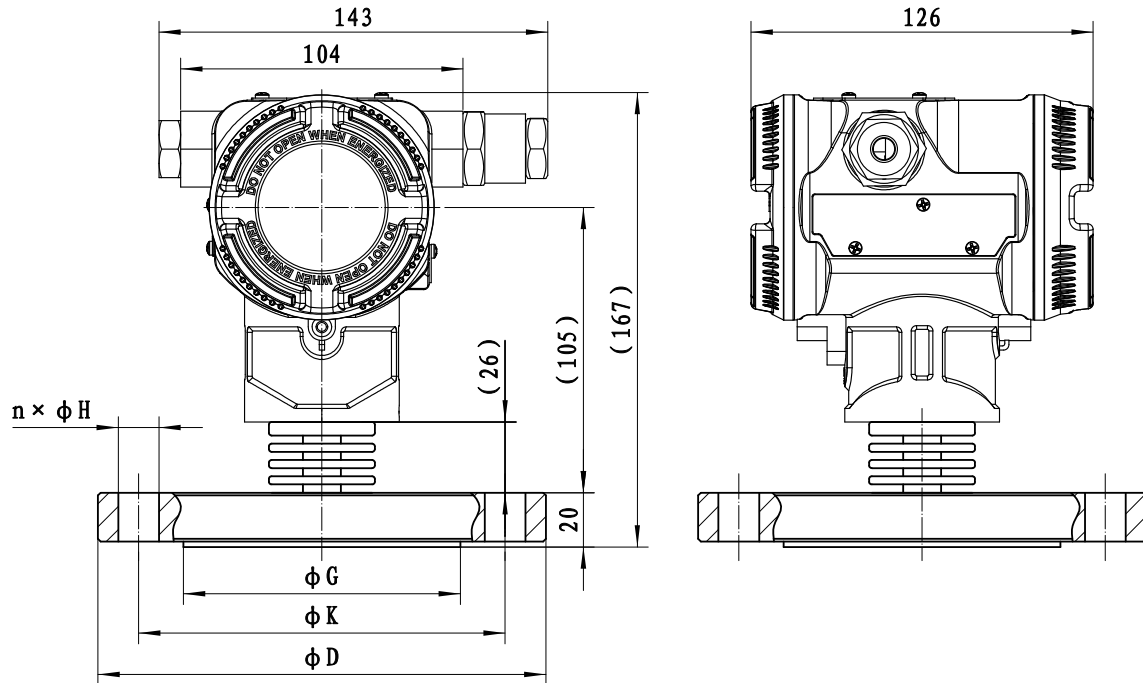

MDM7000 Without Display (Heatsink connection)

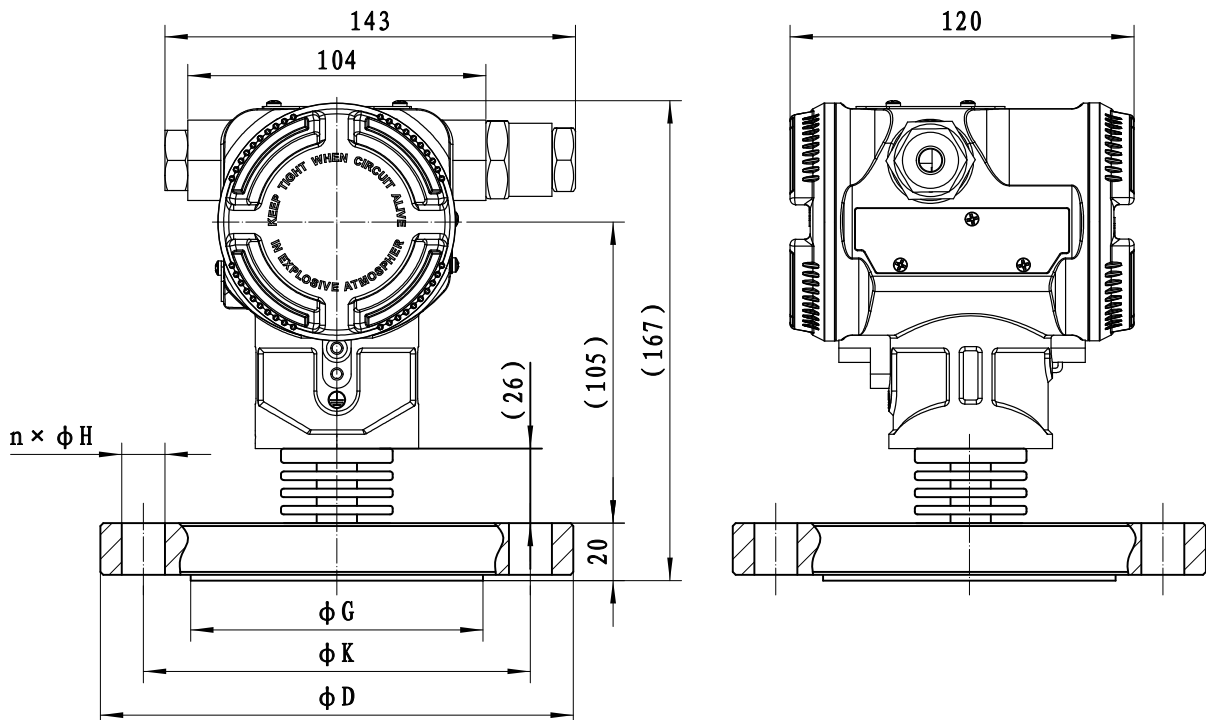

MDM7000 With Display (Capillary tube Connection)

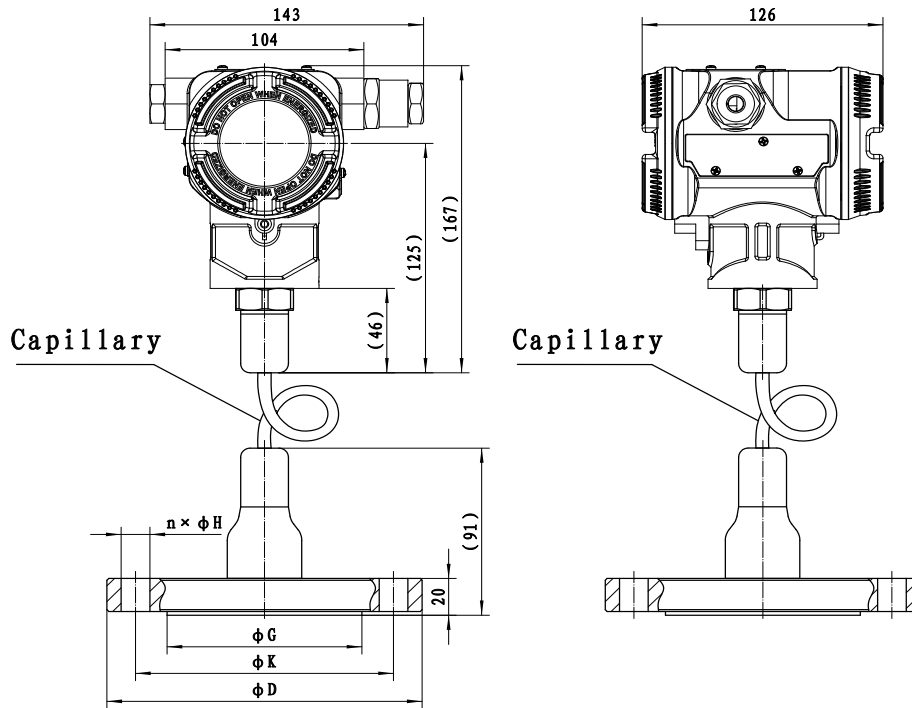

MDM7000 Without Display (Capillary tube Connection)

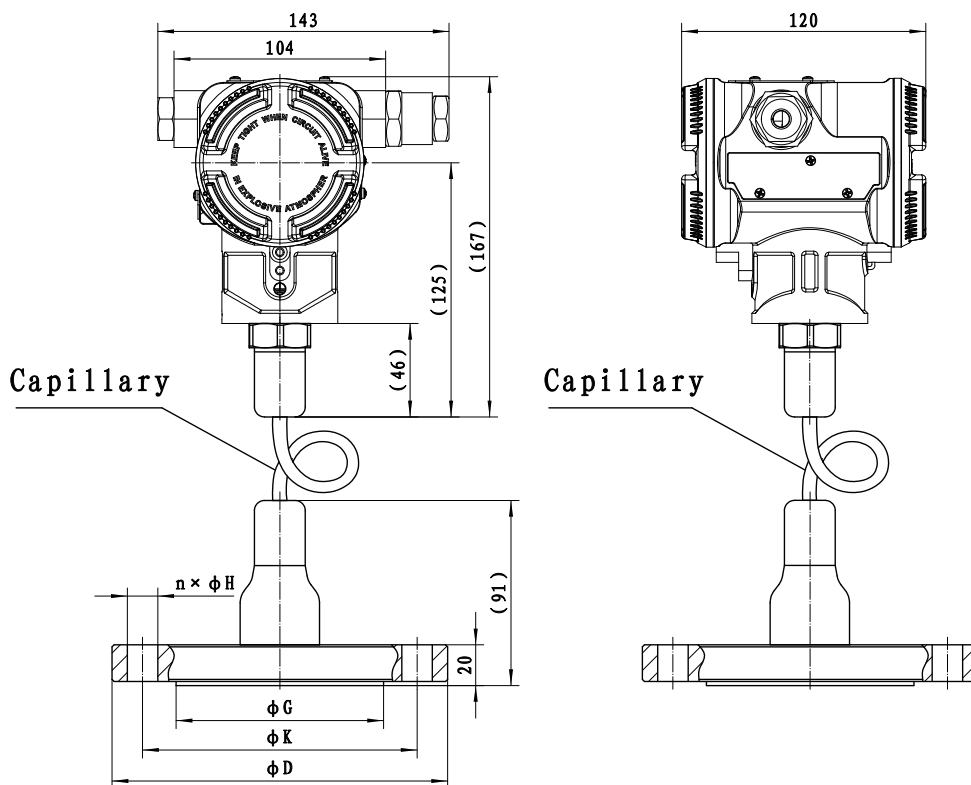

Process Connection (H01,H05,H06)

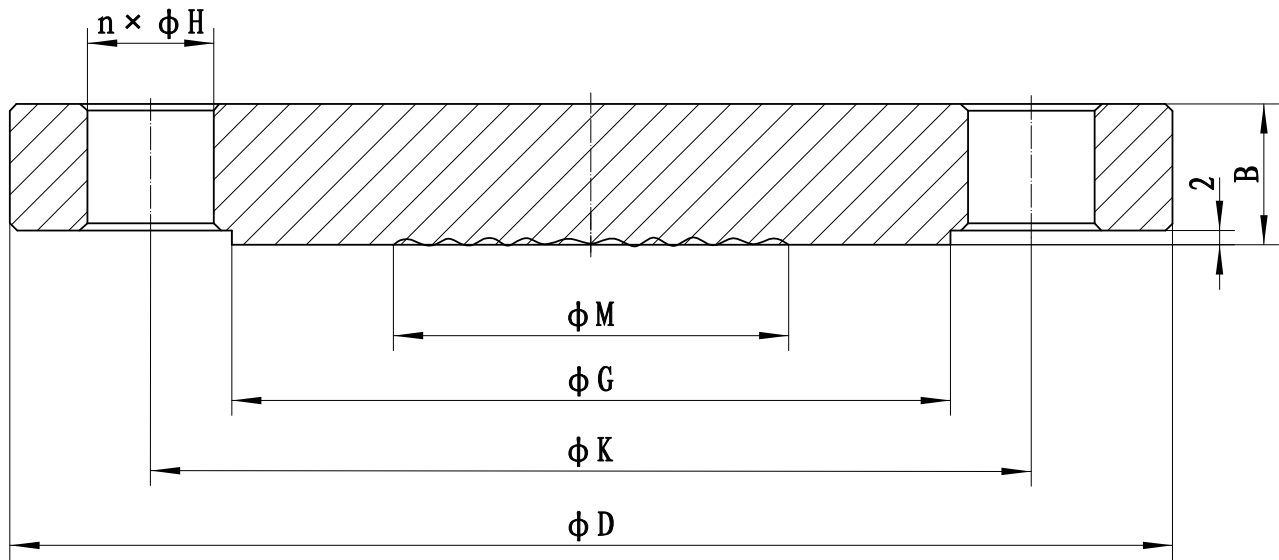

Standard	Specification	Diameter(ϕD)	Thickness(B)	Hole circumference(ϕK)
HG/T20592-2009	DN50PN10	165	20	125
HG/T20592-2009	DN80PN10	200	20	160
HG/T20592-2009	DN100PN10	220	20	180
Convexity diameter(ϕG)	Hole diameter (ϕH)	Quantity(n)	Corrugation diameter(ϕM)	
102	18	4	56	
138	18	8	56	
158	18	8	56	

Order Guide

Items	Parameter	Code	Description
	Model	MDM7000-GP-T/AP-T	Smart Flange Mounted Gauge/Absolute Pressure Rransmitter
Sensor	Separator	-	Detailed specifications as following
	GP -T range	S403G	Nominal value(URL): 0.4bar
		S254G	Nominal value(URL): 2.5bar
		S105G	Nominal value(URL): 10bar
		S305G	Nominal value(URL): 30bar
		S106G	Nominal value(URL): 100bar
	AP-T range	S403A	Nominal value(URL): 0.4bar
		S254A	Nominal value(URL): 2.5bar
		S105A	Nominal value(URL): 10bar
	Sensor seal	F	Stainless steel welded seal
Electrical Connection	Separator	-	Detailed specifications as following
	Cable outlet protection	R1	A waterproof connector M20×1.5 at one side and a gland at the opposite side, PVC material, applicable for 6mm~8mm diameter cable, IP67
		R2	Flame proof, 1/2 NPT (F) at one side, gland at the opposite side, stainless steel material, applicable for 6mm~8mm diameter cable, IP67
		R3	Flame proof, M20×1.5 (F) at one side, gland at the opposite side, stainless steel material, applicable for 6mm~8mm diameter cable, IP67
		R7	Flame proof, G1/2 (F) at one side,gland at the opposite side, stainless steel material, applicable for 6mm~8mm diameter cable, IP67
Output	Separator	-	Detailed specifications as following
	Output signal	H	4mA~20mA DC+HART two wire, power supply:16.5V~55V DC
		B	4mA~20mA DC+HART two wire, Intrinsically safe, power supply:18.5V~28V DC
	Display	A	Without LCD display
		C	LCD display
Process connection	Separator	-	Detailed specifications as following
	Wetted parts material	6	SUS316
		4	SUS304
	Connection type	NT	Standard connection
		HT	Heat sink connection
		FT	Fixed capillary connection
		UT	Capillary connection
	Capillary type	M1	Armoublue SUS304, with PVC cover
		M2	Armoublue SUS304, outer diameter 3.5mm
		M0	None

	Capillary length	XX	XX value range: 0~10, samples: 2=2 meters; 10=10meters	
		0	None	
	Diaphragm material	S	SUS316L	
		T	Tantalum (process connection material can only be SS316)	
		H	Hastelloy C (process connection material can only be SS316)	
		L	SUS316L + gold plated	
		E	SUS316L+Electrolytic polishing	
		P	SUS316L + PTFE(Diaphragm diameter≥31.1mm, Range≥1bar)	
		Fill oil	S	Silicone oil
	H		High-temperature silicone oil	
	F		Hygienic filler, Neobee M-20, pass the FDA sanitary permit	
	Flange connection	H01	HG/T 20592-2009 DN50PN10~PN40 RF raised face flange	
		H05	HG/T 20592-2009 DN80PN10 RF raised face flange	
H06		HG/T 20592-2009 DN100PN10 RF raised face flange		
options	Separator	-	Detailed specifications as following	
	Fixed mounting accessories	/B9	Bracket, SS304	
		0	None	
	Validation report	/Q1	Calibration report provided by MicroSensor	
		0	None	
	Flameproof certification	/E1/AT	Flameproof certification, ATEX certification	
		/E1/IE	Flameproof certification, IECEx certification	
		/E1/PC	Flameproof certification, PCEC certification	
		/E2	Flameproof certification, CSA certification	
		0	None	
	Intrinsically safe certification	/I1/AT	Intrinsically safe certification, ATEX certification	
		/I1/IE	Intrinsically safe certification, IECEx certification	
		/I1/PC	Intrinsically safe certification, PCEC certification	
		0	None	
	CCS certification	/CCS	CCS certification	
		0	None	
	Wetted parts treatment	/G1	Ungrease treatment	
		0	None	
	Note: Please consult the engineer for product certification details.			

Certifications

RoHS		CE
The name of the certification organization		TÜV SÜD
License scope	MDM7000 Series smart Pressure Transmitters	
mark	RoHS	CE
directives	2015/863/EU	2014/30/EU
Verification criteria	IEC62321-1:2013 IEC62321-5:2014 IEC62321-2:2013 IEC62321-6:2015 IEC62321-4:2014 IEC62321-7-1:2015	EN IEC 61326-1:2021

Flameproof certification		
The name of the certification organization	PCEC	CSA
License scope	MDM7000 Series smart Pressure Transmitters	
Explosion-proof signs	Ex db IIC T6 Gb	Class I, Division 1, Group A, B, C and D T6 Class II, Division 1 Group E, F and G T70°C Class III
Use ambient temperature	-40°C ~70°C	-40°C ~70°C

Intrinsically safe certification	
The name of the certification organization	PCEC
License scope	MDM7000 Series smart Pressure Transmitters
Explosion-proof signs	Ex ia IIC T4 Ga
Use ambient temperature	-40°C ~70°C
Description of intrinsically safe parameters	Maximum input voltage U_i (V): 28
	Maximum input current I_i (mA): 100
	Maximum input power P_i (W): 0.7
	Highest internal equivalent parameter C_i (nF): 20
	Highest internal equivalent parameter L_i (μH): 20